

Batch Freezer

The batch freezers are available in one and two-door configuration and are designed to operate with liquid nitrogen (LN₂). The freezers are capable of freezing and chilling a wide variety of products:

- **Meat**
- **Poultry**
- **Seafood**
- **Prepared entrees**
- **Bagels**
- **Pizza**

Key benefits of Nippon Sanso Matheson Batch Freezer:

- Low cryogen and power consumption
- Automatic temperature control
- Quick cool-down
- Low maintenance requirements
- Customizable stainless steel or aluminum tray configurations
- Optional stainless steel tray carts, wheeled carts and transfer dollies
- Optional proportional temperature control
- Meets USDA and OSHA requirement

Specifications:

Double door freezer dimensions (H x W x D):	62" x 92" x 40"
Single door freezer dimensions (H x W x D):	62" x 45" x 40"
Dolly dimensions (HxWxD):	58" x 18-1/4" x 29-1/4"
Capacity:	19 trays per dolly
Tray dimensions:	18" x 26"
Freezer construction:	Stainless Steel
Electrical requirements:	110V/1Ø or 230/460V/3Ø



**NIPPON
SANSO**

Single Door Batch Freezer

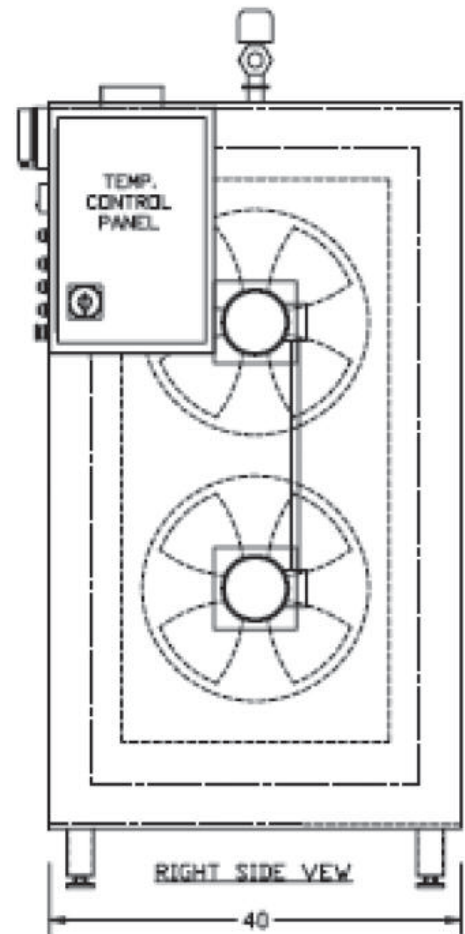
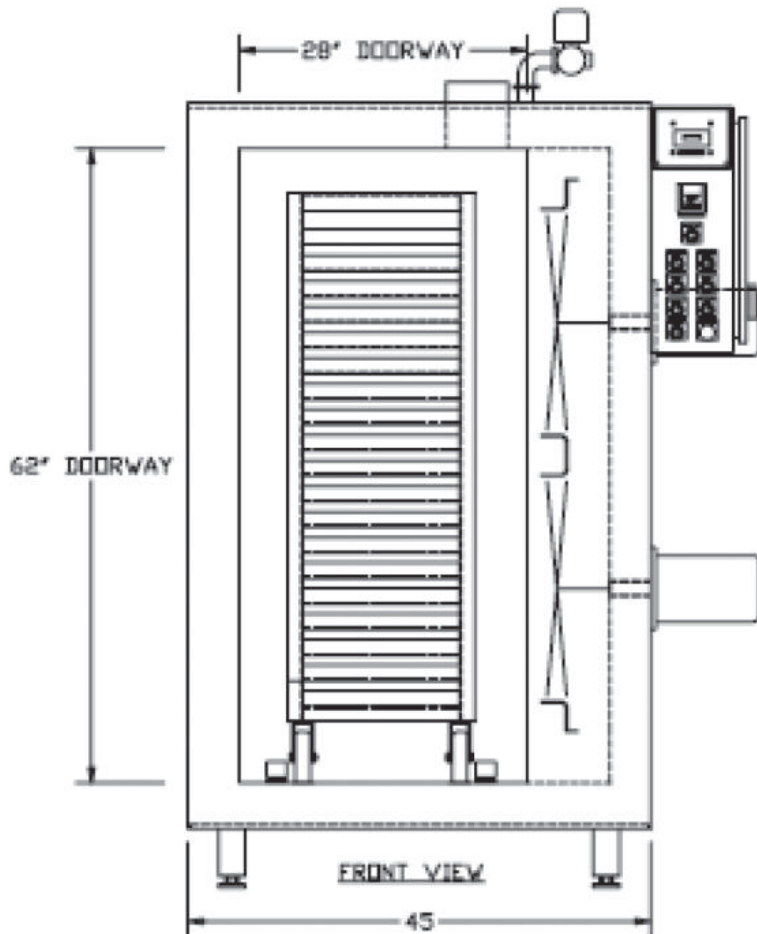
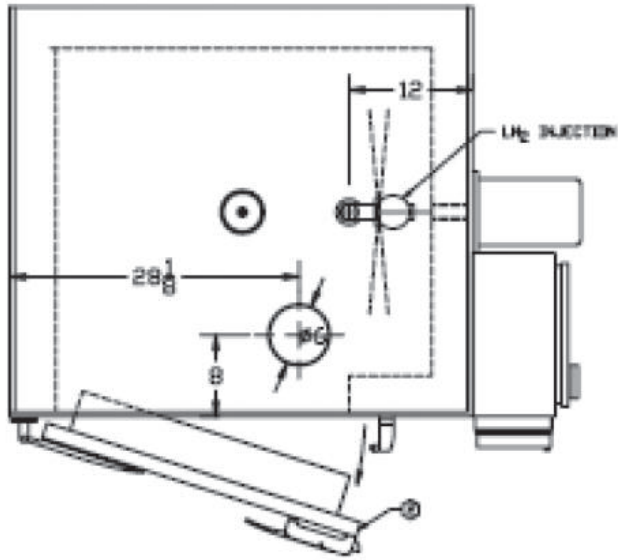

Two Door Batch Freezer

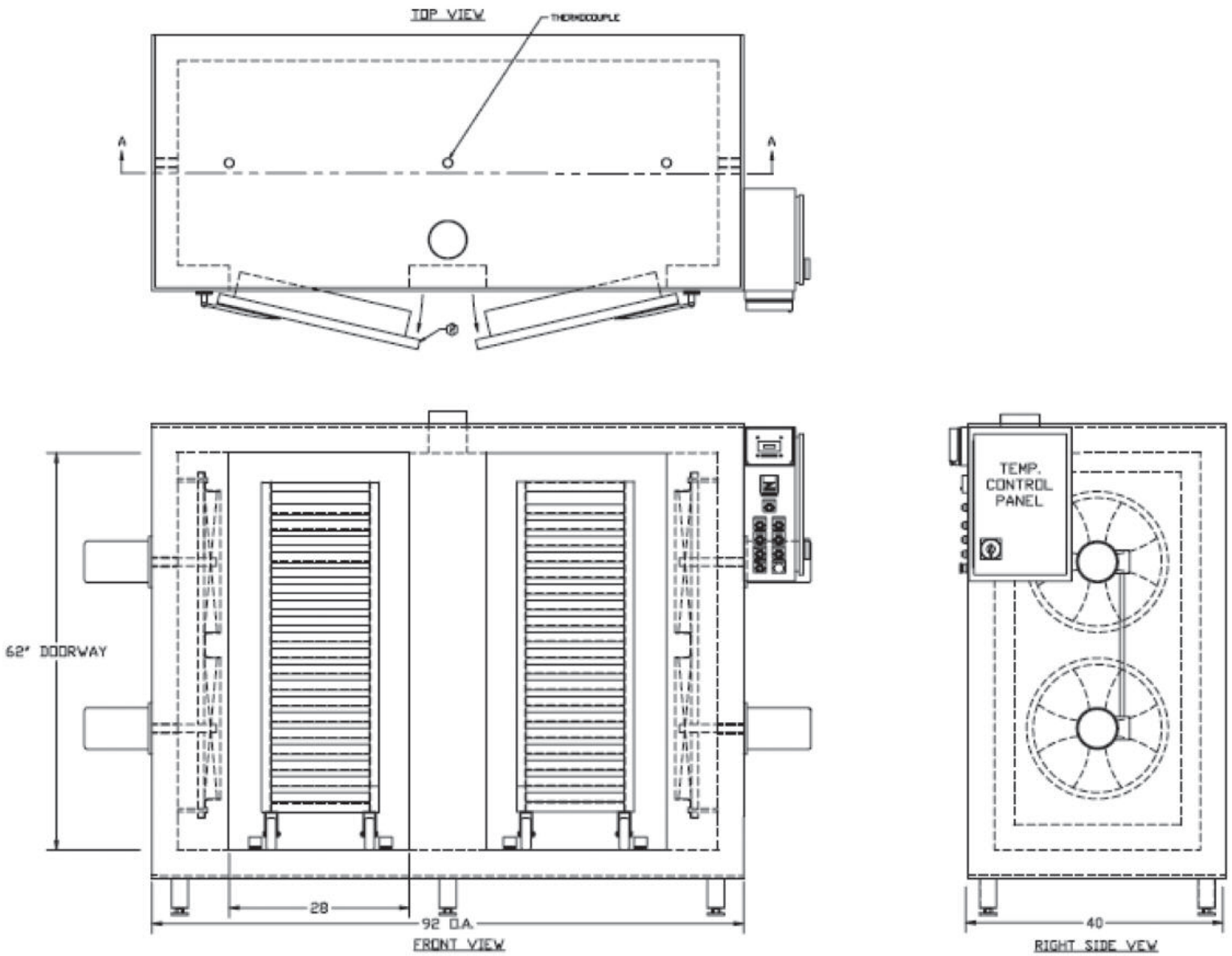

Specifications are subject to change. Please check www.us.nipponanso.com for most current information.

TB412 03/2026

