

Nippon Sanso Matheson's LaserPro™ Gases and Gas Delivery Equipment for Metal Fabrication



**NIPPON
SANSO**

Nippon Sanso Matheson's LaserPro™ Support Gases and Services



High Pressure, High Flow Liquid Cylinders

Nippon Sanso Matheson delivers the LaserPro™ line of gases specifically designed to meet the stringent purity requirements for use in lasers. Impurities have a negative effect on laser beam performance, and Nippon Sanso Matheson produces the LaserPro™ line of laser gases to meet or exceed the purities demanded by laser manufacturers and users.

We supply laser support gases in bulk, tube trailers, microbulk, liquid Dewars, high pressure cylinders and multipacks. Our qualified laser experts can determine and recommend the best method for delivering laser gases to meet the specific flow and pressure parameters for your laser.

As a leading supplier of laser gases, Nippon Sanso Matheson has the experience and expertise to make your operation productive and profitable.

Nippon Sanso Matheson delivers:

- A complete line of high purity gas products, specifically designed for lasers, including laser assist and process gases – in any grade needed to meet your requirements
- Preblended gas mixtures in any composition desired, eliminating the need to mix gases in house
- A total gas supply system, including high quality gas control equipment specifically designed for laser applications
- Customized solutions specific to your requirements
- Complete turnkey laser systems
- Laser support services

Laser Assist Gases

An assist gas is a secondary stream of gas that is used in combination with the primary laser beam. Assist gases play a crucial role in the quality and efficiency of the laser cutting process. Assist gases are typically supplied through a nozzle near the laser beam. The primary purpose of an assist gas is to remove molten material and debris from the cut zone which helps improve the quality and precision of the final product.

There are several types of gases that can be used as laser assist gases. The choice depends on the material being cut and the desired result. Oxygen, Nitrogen, Helium, Argon, and Nitrogen/Oxygen blends are commonly used assist gases.

Nippon Sanso Matheson laser experts will evaluate your application and recommend the best assist gas for your application. Different gases have different properties and react differently with different materials so selecting the appropriate assist gas is crucial.

Nippon Sanso Matheson will also recommend the best supply method for your application, whether it's a multipack, high-pressure cylinder, microbulk, or sophisticated Trifecta® system.

Microbulk



Multipacks



Trifecta® Gas Supply System



Bulk tanks with Trifecta® Supply System

Nippon Sanso Matheson's LaserPro™ Gas Delivery Equipment

Nippon Sanso Matheson's LaserPro™ systems for assist gases are designed to meet and exceed the laser industry's demanding requirements for gas purity, pressure and flow. All of our equipment complements our line of assist gases.

Assist Gas Process Equipment

Assist gases are supplied to the nozzle to assist with cutting by removing the metal that has been heated by the laser beam. Nippon Sanso Matheson's LaserPro™ assist gas equipment provides the high capacity with constant delivery pressures up to 1000 psig. Dome loaded regulators for assist gases are able to provide these flows and pressures with the economical pricing of a single stage regulator and the consistency of a more expensive two stage regulator. These are available for both cryogenic and high-pressure sources.

Lasers may require not only high pressures, but also high flowrates of gas. Pressures may be up to 450-500 psig and flowrate requirements may be up to 6000 scfh and greater.

In addition to regulators, we offer wall mounting and installation kits, including hoses, fittings, and filters.



Assist Gas Equipment

The model **LPHF Assist Gas Regulators** deliver high pressure and high flow of Nitrogen Oxygen, Argon and Helium. The key to the performance of this regulator is the servo-dome load technology. The servo-dome load feature allows the regulator to supply high flow rates with straight line pressure regulation. The LPHF series is constructed of brass barstock, with PTFE seats and seals. The maximum inlet pressure is 3000 psig (optional 5500 psig).

Features:

- 250, 500, or 1000 psig delivery pressure
- Fast on/off response, even at high flow
- 3000 psig inlet pressure (5500 psig optional)
- Tamper proof, self-reseating internal safety valve on 250 and 500 psig models only
- One piece encapsulated seat design with 10 micron filtration
- 1/2" NPT female inlet / outlet
- Conforms to CGA E-4 standard for gas pressure regulators

Specifications:

- Cv: LPHF: 0.55 LPCR: 0.37 LP701: 0.17
- Maximum Flow Rate: 6000 scfh Air LPHF series (inlet > 400 psig)
2500 scfh Air LPCR series (inlet > 400 psig)
1000 scfh Air LP701 series (inlet 2000 psig)
- Pressure Regulation*: 0 psig/100 psig for 250 and 500 psig delivery pressure
(LPHF SERIES) 0 psig/100 psig for 1000 psig delivery pressure
- Weight: LPHF: 8.5 lbs LP701: 3.5 lbs. LPCR: 3.1 lbs

*Delivery pressure change per cylinder pressure decay



LPHF Series for High Pressure and Cryogenic Source



LPCR Series for Cryogenic Source

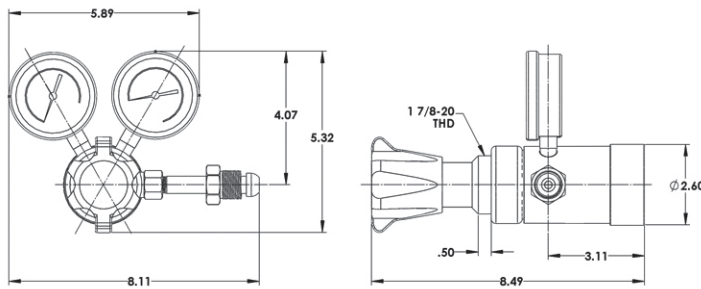

LPHF Series

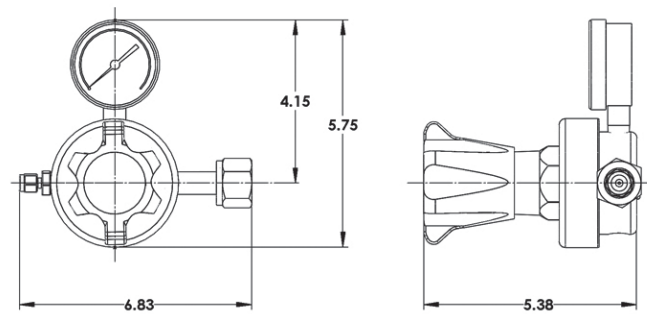

LPCR Series

Assist Gas Equipment

Ordering Information:

SEQ LPHF250580	Nitrogen, Argon and Helium, 0-250 psig delivery range, CGA 580 inlet, 1/2" FNPT outlet, internal relief valve, 10 micron inlet filter, Cv = 0.55
SEQ LPHF250540	Oxygen, 0-250 psig delivery range, CGA 540 inlet, 1/2" FNPT outlet, internal relief valve, 10 micron inlet filter, Cv = 0.55
SEQ LPHF500580	Nitrogen, Argon and Helium, 0-500 psig delivery range, CGA 580 inlet, 1/2" FNPT outlet, internal relief valve, 10 micron inlet filter, Cv = 0.55
SEQ LPHF500540	Oxygen, 0-500 psig delivery range, CGA 540 inlet, 1/2" FNPT outlet, internal relief valve, 10 micron inlet filter, Cv = 0.55
SEQ LPHF1000580	Nitrogen, Argon and Helium, 0-1000 psig delivery range, CGA 580 inlet, 1/2" FNPT outlet, 10 micron inlet filter, Cv = 0.4
SEQ LPHF1000540	Oxygen, 0-1000 psig delivery range, CGA 540 inlet, 1/2" FNPT outlet, 10 micron inlet filter, Cv = 0.4
SEQ LPHF250NI	0-250 psig delivery range, 1/2" FNPT inlet, 1/2" FNPT outlet, internal relief valve, 10 micron inlet filter, Cv = 0.55
SEQ LPHF500NI	0-500 psig delivery range, 1/2" FNPT inlet, 1/2" FNPT outlet, internal relief valve, 10 micron inlet filter, Cv = 0.55
SEQ LPHF1000NI	0-1000 psig delivery range, 1/2" FNPT inlet, 1/2" FNPT outlet, 10 micron inlet filter, Cv = 0.4
SEQ LP701250540	0-250 psig delivery range, 1/4" FNPT inlet, 1/4" FNPT outlet, 10 micron inlet filter, Cv = 0.17

Related Options:

SEQ LPHFPMN	Panel mount nut (LPHF series only)
SEQ LPHFWMBR	Wall mount bracket (LPHF series only)
SEQ 6086580	Stainless steel flex hose, 1/2" ID, 6', CGA 580 inlet, 1/2" NPTM out, 3500 psig MAWP
SEQ 6086540	Stainless steel flex hose, 1/2" ID, 6', CGA 540 inlet, 1/2" NPTM out, 3500 psig MAWP

Cylinder Adapter Kits:

SEQ 5804P8P	CGA 580 adapter kit, CGA 580 with 1/4" NPT female to 1/2" NPT male
SEQ 5404P8P	CGA 540 adapter kit, CGA 540 with 1/4" NPT female to 1/2" NPT male

Assist Gas Equipment

Basic Laser Gas Kit

Applications

Nippon Sanso Matheson's LaserPro™ Universal Basic Laser StartUp Kits provide the most common equipment necessary for supplying assist gases to the laser. Basic kits contain a high-flow, dome-loaded regulator for Nitrogen, Oxygen, Argon or Helium assist gas, high-capacity hoses for the assist gas, and various fittings and filters to help with the laser installation.



Basic Assist Gas Kits

SEQ LPNAG25025	LaserPro™ Nitrogen, Argon and Helium assist gas kit, 250 psig delivery pressure
SEQ LPNAG50025	LaserPro™ Nitrogen, Argon and Helium assist gas kit, 500 psig delivery pressure
SEQ LPOAG25025	LaserPro™ Oxygen assist gas kit, 250 psig delivery pressure
SEQ LPOCAG25025	LaserPro™ Oxygen assist gas kit, Liquid Cylinders, 250 psig delivery pressure, with LPCR regulator

Each kit consists of:

Assist Gas Regulator: See regulator listings for model numbers / delivery pressures

SEQ LP25HS	25' of high flow capacity hose, rated to 2000 psig
SEQ LPFTR90	90 micron "T" filter
SEQ LPADPFP	3/4" flair x 1/2" NPT male fitting
SEQ LPADP84	1/2" MNPT x 1/4" MNPT
SEQ LPADPFBS	3/4" flare x 1/2" bspp

Options:

SEQ LP50HS	50' of high flow capacity hose, rated to 2000 psig
SEQ 60838PF8PF	Stainless steel flex hose, 3, 1/2" ID, 1/2" NPT female in/out
SEQ 608108PF8PF	Stainless steel flex hose, 10, 1/2" ID, 1/2" NPT female in/out
SEQ LPHFWMBR	Wall mount bracket for LPHF series regulators

Nippon Sanso Matheson's LaserPro™ Delivers

Nippon Sanso Matheson Delivers Safety

Nippon Sanso Matheson places the highest value on Safety – in our own facilities, and in yours. Every day.

- We value our safety record, and we've received many industry awards for our safe operations.
- We offer a full range of products for safe handling and storage of gas ... as well as a complete line of safety equipment.
- Invite us to perform a safety audit of your facility and/or conduct a safety presentation.

Nippon Sanso Matheson Delivers Quality

Nippon Sanso Matheson also places the highest value on Quality. Our plants are certified to ISO 9001 standards, and we employ Lean Six Sigma (LSS) principles to measure and improve our quality results on a basis of continuous improvement.

Nippon Sanso Matheson Customer Service

Throughout our history of serving customers, Nippon Sanso Matheson has always placed a premium value on the relationship we build and maintain with every one of our customers. We have over 300 locations nationwide ready to serve you.

- Ask us about enhanced supply chain management.
- Ask us about on-line ordering and certificates of analysis.
- Ask us how we can lower your cost of ownership and gas use.

Nippon Sanso Matheson Delivers Sustainability

Nippon Sanso Matheson is committed, at all levels, and in all locations, to principles of Sustainability and Corporate Responsibility. Our principles embrace Environmental Sensitivity, Community Support, and Financial Performance. Our aim is to ensure uninterrupted access to our products and services.



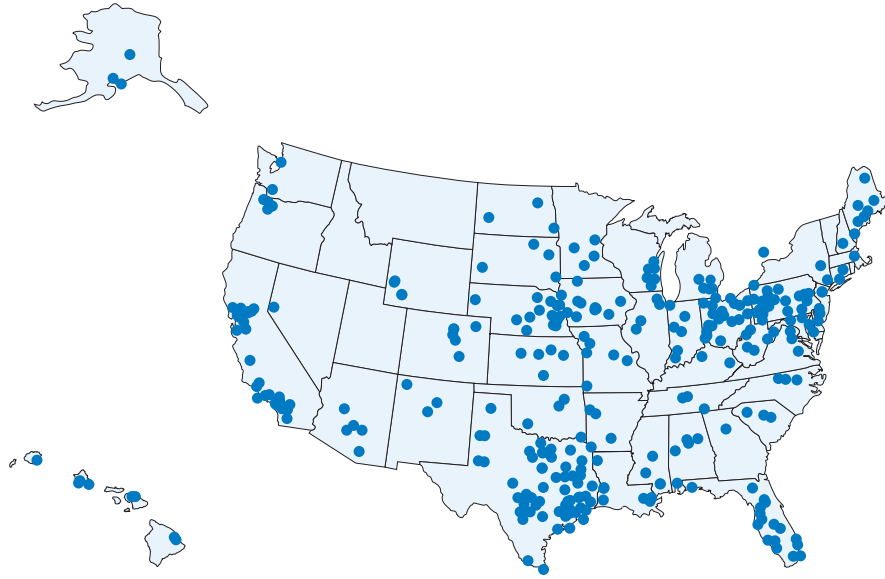

Over 300 locations coast-to-coast.



**www.us.nipponsanso.com
800-416-2505**

Copyright 2026 Nippon Sanso Matheson, Inc. All Rights Reserved.

All contents of this document are subject to change without notice and do not represent a commitment on the part of Nippon Sanso Matheson, Inc. Every effort is made to ensure the accuracy of this information. However, due to differences in actual and ongoing operational processes and product improvements and revisions, Nippon Sanso Matheson, Inc. cannot guarantee the accuracy of this material, nor can it accept responsibility for errors or omissions. This document is intended to serve as a general orientation and cannot be relied upon for a specific operation. No warranties of any nature are extended by the information contained in these copyrighted materials.

All names, products, and services mentioned herein are the trademarks or registered trademarks of their respective organizations and are the sole property of their respective owners. Nippon Sanso Matheson and Nippon Sanso Matheson logo are registered trademarks of Nippon Sanso Matheson, Inc.

BR 269 03/2026