



Introduction

Regulators

Regulators are used in gas delivery systems to reduce the pressure from a high pressure source to a safe working pressure for use. A pressure regulator should always be used when positive control of the pressure in a gas stream is required. A pressure regulator is as much a safety device as it is an important tool. All Nippon Sanso Matheson regulators are cleaned for oxygen service except as noted.

Basic Regulator Types

There are two basic types of pressure regulators: a single stage type and a dual stage type. The outward appearance of the two distinctly different types is somewhat similar and may be difficult to distinguish. Most pressure regulators are fitted with two gauges to monitor pressures (most line regulators only have one). Established convention in the United States and Canada has situated the high pressure gauge being connected internally to the inlet side of the regulator (the right side of the regulator when facing from the front). This gauge is used to monitor the source pressure. The low pressure gauge connected internally to the outlet side of the regulator is situated on the left side of the regulator when facing from the front. This gauge is used to monitor the outlet pressure (this is the gauge commonly installed on most regulators).

On occasion, an outlet valve is affixed to the outlet port of the regulator. This valve is to be used to turn the flow of gas on or off for brief periods of time. It should never be used to throttle or control the flow of gas emitted from a regulator. This practice could cause serious damage to both the regulator and its operator. Flow should always be controlled by some other piece of equipment such as a rotameter or mass flowmeter.

DUAL STAGE regulators reduce the source pressure down to the desired delivery pressure in two steps. Each stage consists of a spring, diaphragm, and control valve. The first stage reduces the inlet pressure to about three times the maximum working pressure. The final pressure reduction occurs in the second stage.

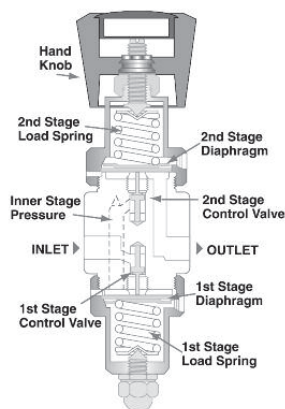

The advantage of a dual stage regulator is its ability to deliver a constant pressure, even with a decrease in inlet pressure. For example, as a cylinder of gas is depleted, the cylinder pressure drops. Under these conditions, single stage regulators exhibit a “decaying inlet characteristic”; where the delivery pressure increases as a result of the decrease in inlet pressure. In a dual stage regulator, the second stage compensates for this decrease, providing a constant delivery pressure regardless of inlet pressure conditions. The dual stage regulator is recommended for applications where a continuous supply of gas is required; such as the gas supplied to analytical instruments where constant delivery pressure is critical.

SINGLE STAGE regulators perform the same function as the two stage regulator using a single step reduction of source to outlet pressure. For this reason, the outlet pressure cannot be as accurately controlled as the source pressure decays. We highly recommend single stage regulators only be used in circumstances where the operator can monitor and adjust the regulator as needed or where the regulator is supplied a nearly constant source pressure.

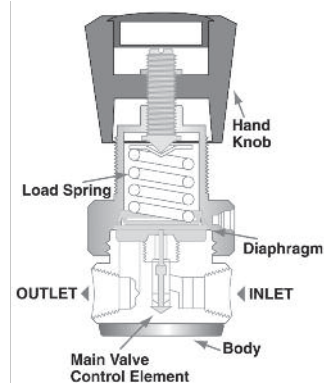

LINE REGULATORS are single stage regulators that are used to provide point-of-use pressure monitoring and control. For example, a lab may have gas cylinders located in a room on the first floor. The gas may be piped to instruments located in a lab on the second floor. In this case, it is difficult to monitor the gas pressure directly at the instruments, since the regulators are located on the cylinders on the first floor. A line regulator may be installed near the instruments for convenience of monitoring the delivery pressure at the point of use. These regulators are installed directly into gas lines, and have a single delivery pressure gauge.

Gauges

Gauges are used to monitor the pressure within a gas delivery system. The basic component of a gauge is a hollow metal tube that expands and contracts a very exact amount under varying pressures. This tube is connected to the part of the gauge usually screwed into a regulator and is also connected to a series of gears. These gears are further connected to a needle, which is what the user can view at the front of the gauge.

Nippon Sanso Matheson Regulators

GENERAL PURPOSE – These products are suitable for applications where cost is an overriding factor. Generally, these products are best suited to applications involving gases that are less than 99.995% purity level (for pure gases) or unanalyzed mixtures. Also, these products should not be used when there is a concern of moisture, air or hydrocarbon contamination to the gases under control.

HIGH PURITY – These products are suitable for applications where maintaining the purity of a gas or mixture is the overriding concern. Generally, these products are best suited to applications involving gases that are greater than 99.995% purity level (for pure gases) or analyzed mixtures. These products are also highly recommended when dealing with more hazardous gases that are either corrosive, toxic or pyrophoric. Typically these products are used in analytical laboratory applications or special process situations.



Introduction *(continued)*

ULTRA-LINE® – Primarily Semiconductor Grade, these products are suitable and highly recommended for applications where the highest obtainable purity and the least risk of contamination is absolutely necessary. Typically, this describes all of the applications associated with the Semiconductor manufacturing industry and also has applications in the Pharmaceutical and Chemical Processing industries.

High Purity Features

The features of a regulator determine the type of service for which it can be used. A regulator intended for a high purity application has different features than a unit designed for general purpose use. Three main features determine the suitability of a regulator for high purity applications:

Body Type: Regulator bodies may be of forged or barstock construction. Barstock bodies are used for high purity applications for the following reasons:

Reduced internal volumes: Because barstock bodies are machined, it is possible to achieve a small internal cavity in the regulator body. The low internal volume makes purging the regulator easy, allowing for removal of contaminants like moisture and oxygen.

Tight grain structure of the metal: The cold drawing process produces metal barstock with a very tight grain structure. This tight grain structure prevents the regulator's internal surfaces from adsorbing moisture and contaminants, allowing them to be purged easily.

Low Ra surface finish: The machining process allows for very low Ra (Roughness Average) surface finishes on the barstock. The low Ra finish minimizes particle shedding, which contributes to contamination.

Diaphragm Material: Diaphragms may be constructed of elastomers (neoprene, Viton, etc.) or stainless steel. Stainless steel diaphragms are used in high purity regulators because they do not adsorb and release (or “offgas”) contaminants. When a regulator is removed from a cylinder, it is exposed to ambient air. An elastomeric diaphragm will adsorb moisture and any other contaminants from the air. When the regulator is put back into service, the elastomeric diaphragm releases these contaminants, which are diffused back into the gas delivery system. A stainless steel diaphragm is unable to adsorb any contaminants, so it does not contribute to system contamination.

Type of Seals: The seal between the body of the regulator and the diaphragm is important in maintaining purity. A poor seal creates a leakage point through which contaminants may enter the gas delivery system. A metal to metal seal (metal regulator body sealing to a metal diaphragm) is the most reliable, leak-free type of seal. An elastomeric diaphragm can degrade over time, compromising the integrity of this seal.

Helium Leak Testing

A complete Helium Leak Test involves the monitoring of both the inboard leakage of an item and the outboard leakage of an item. Inboard leak tests are performed by drawing an internal vacuum on the equipment (under test), while surrounding it with helium, then monitoring the helium leakage rate from the outside to the inside. Outboard leak tests are performed by pressurizing the subject item with helium and analyzing the surrounding space for the presence of helium. Upon completion of the test, a certificate is written and forwarded with the item to the customer. In the case where 100% of the items are leak tested, a Certificate of Conformance can be requested for the item.

NOTE: Economy regulators with rubber diaphragms cannot be helium leak tested.